

TA507B

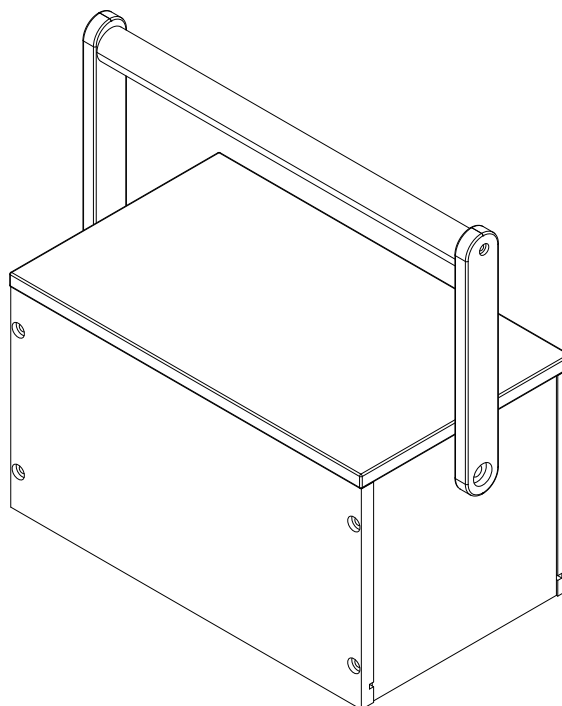

 **WARNING:**
CHOKING HAZARD - Small parts.
Not for children under 3 years. Adult assembly required.



NOTE : Please read instructions before assembly

NOTE ①

Be smart-sort your parts!

Be sure you have all required parts BEFORE beginning assembly!

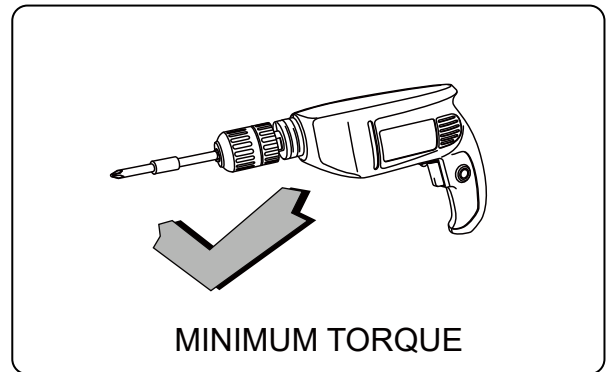
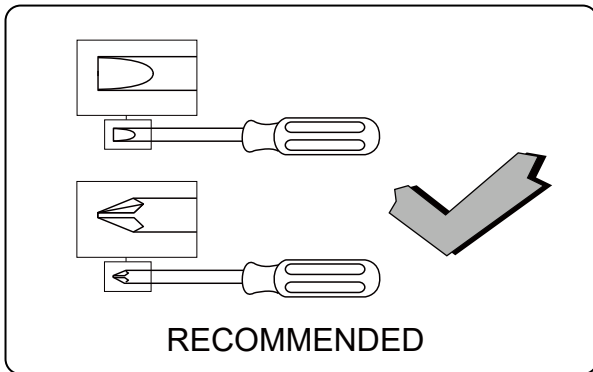

Please use a manual screwdriver for assembly or set the electric screwdriver to the **MINIMUM TORQUE** to avoid damaging the product. If the minimum torque is not sufficient to turn the screws, gradually increase the torque as needed.

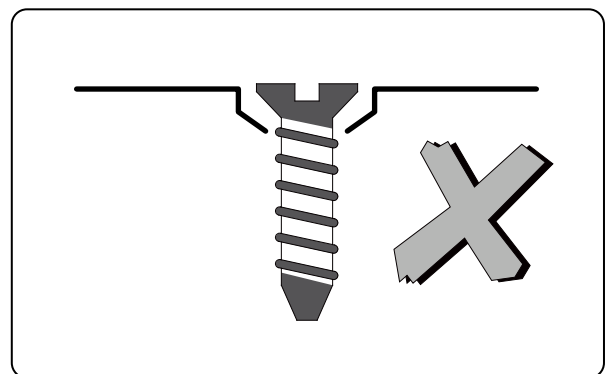
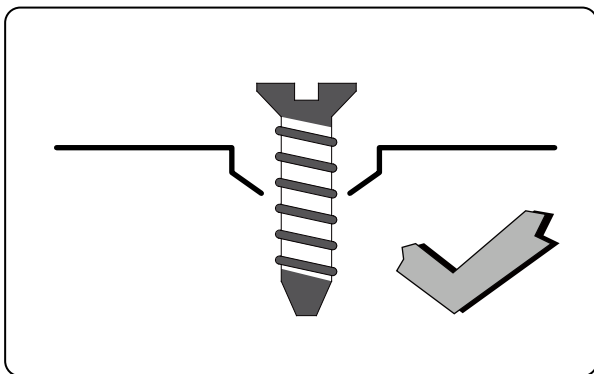

DO NOT FULLY TIGHTEN SCREWS UNTIL ALL PANELS ARE CONNECTED.

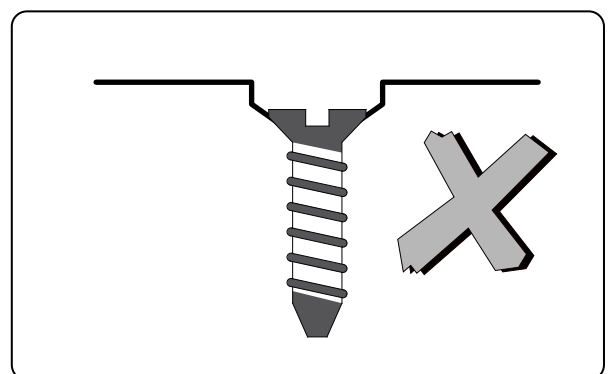
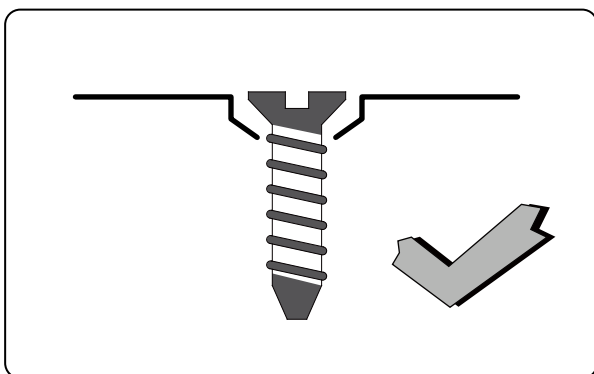

To complete assembly, use a hand-held screwdriver to fully tighten all screws until they're snug.

DO NOT OVER-TIGHTEN!

Over-tightening will cause the product to crack!

NOTE ②

Plastic fasteners are pre-installed! However, they may shift during transportation. Please check whether the fasteners are properly seated in the holes and adjust them if they are misaligned. The correct installation positions are as follows:

short slot long slot

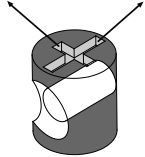

long slot indicates the direction of the screw hole

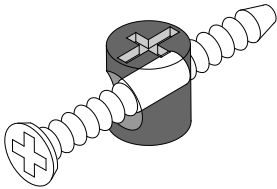

fastener and screw position

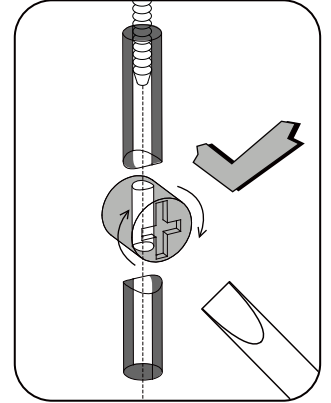
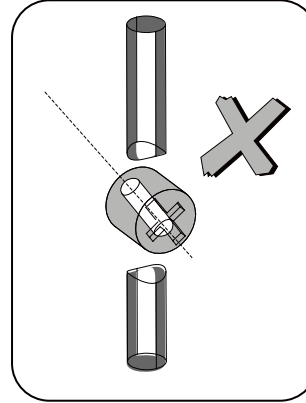

OR

slot indicates the direction of the screw hole

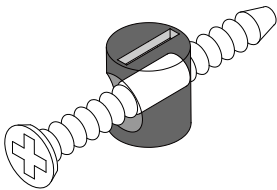

fastener and screw position

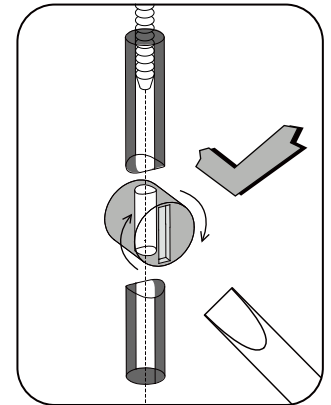
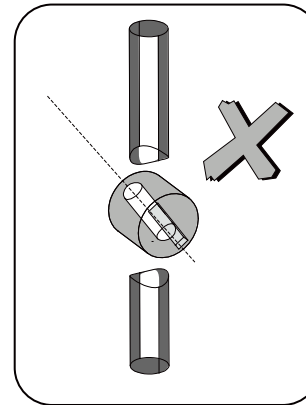

Pay attention to note 2 on assembly steps **A** **B** **D**

- EN** **Warning!** Choking hazard - Small parts. Not suitable for children under 3 years. Adult assembly required.
- DE** **Achtung!** Erstickungsgefahr - Kleine Teile. Nicht für Kinder unter drei Jahren geeignet. moins de trois ans. Der Zusammenbau ist durch einen Erwachsenen vorzunehmen.
- FR** **Attention!** Danger d'étouffement - Petits éléments. Ne convient pas aux enfants de moins de trois ans. Assemblage par un adulte requis.
- ES** **Advertencia!** Peligro de atragantamiento - Partes pequeñas. No conviene para niños menores de tres años. Se requiere ensamblaje por un adulto.
- IT** **Avvertenza!** Rischio di soffocamento - Piccole parti. Non adatto a bambini di età inferiore a 3 anni. Richiesto assemblaggio da parte di un adulto.
- NL** **Waarschuwing!** Verstikkingsgevaar - Kleine onderdelen. Niet geschikt voor kinderen jonger dan drie jaar. Te monteren door een volwassene.
- PT** **Atenção!** Risco de asfixia - Pequenas partes. Contra-indicado para crianças com menos de 3 anos. Necessária montagem por um adulto.
- GR** **Προειδοποίηση!** Κίνδυνος πνιγμού - Μικρά μέρη. Δεν είναι κατάλληλο για παιδιά κάτω των τριών ετών. Απαιτείται συναρμολόγηση από ενήλικα.
- JA** 警告! 窒息の危険-小さな部品の誤飲・窒息の危険がありますので、3歳未満のお子様には絶対に与えないでください。組み立ては大人の方が行ってください。

CONTENTS

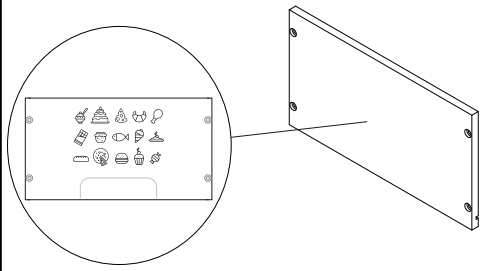

1 X 1pc

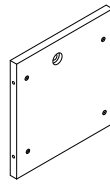

2 X 2pcs

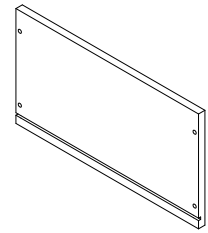

3 X 1pc

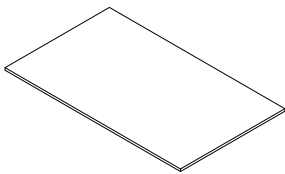

4 X 1pc

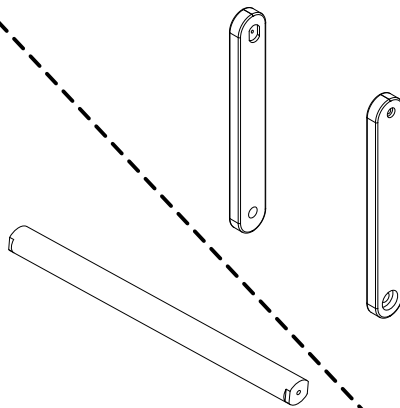

5 X 1pc

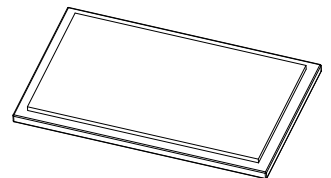

6 X 1pc

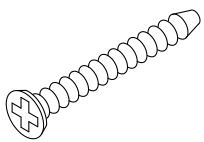

M4X35mm

7 X 10pcs

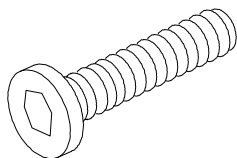

M6X20mm

8 X 2pcs

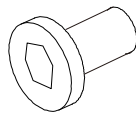

M6X13mm

9 X 2pcs



10 X 2pcs

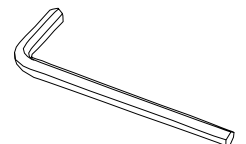

11 X 2pcs

ACCESSORIES

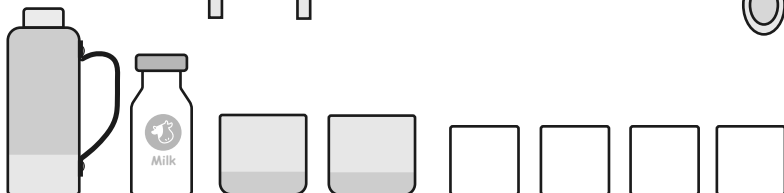
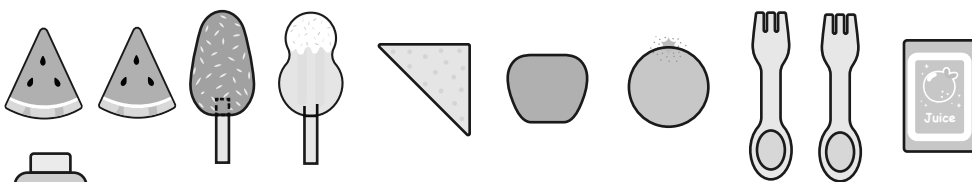

1pc each

A See Note **2**

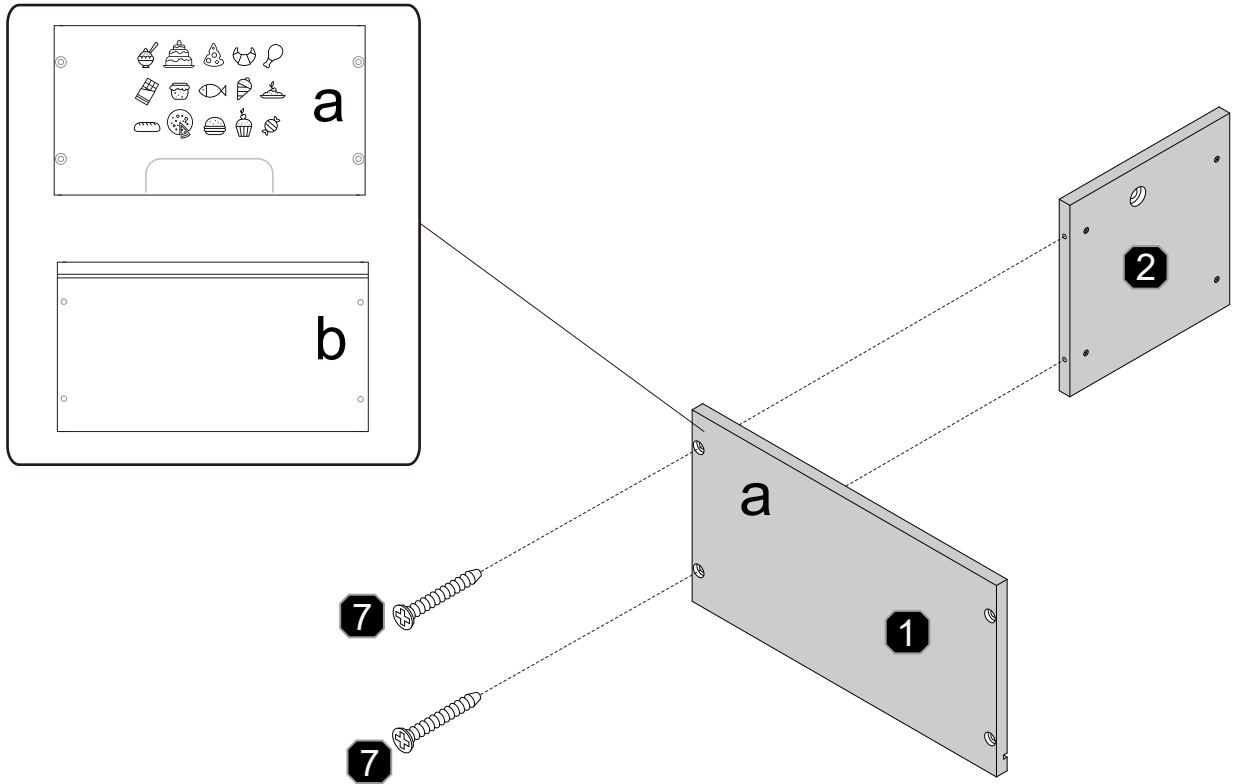

B See Note **2**

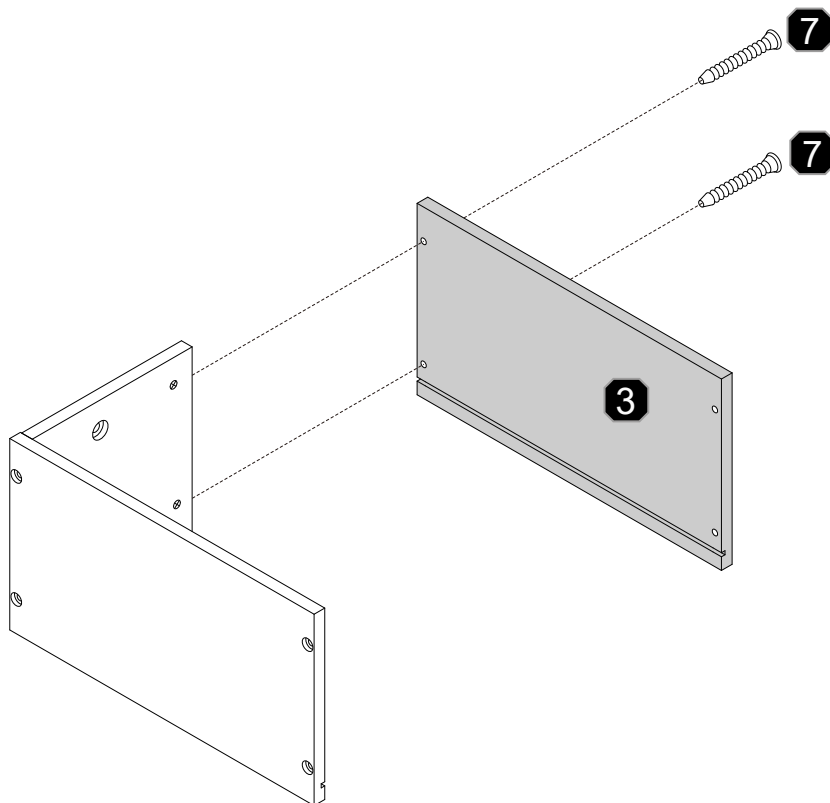

C

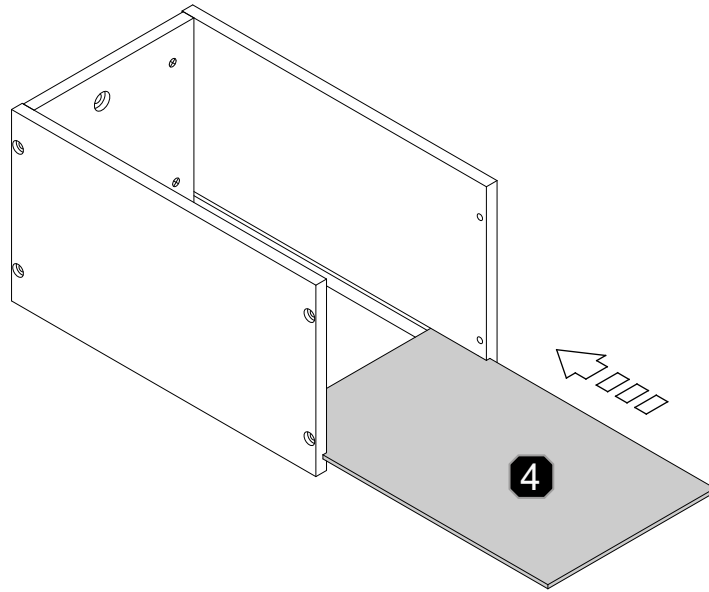

D See Note **2**

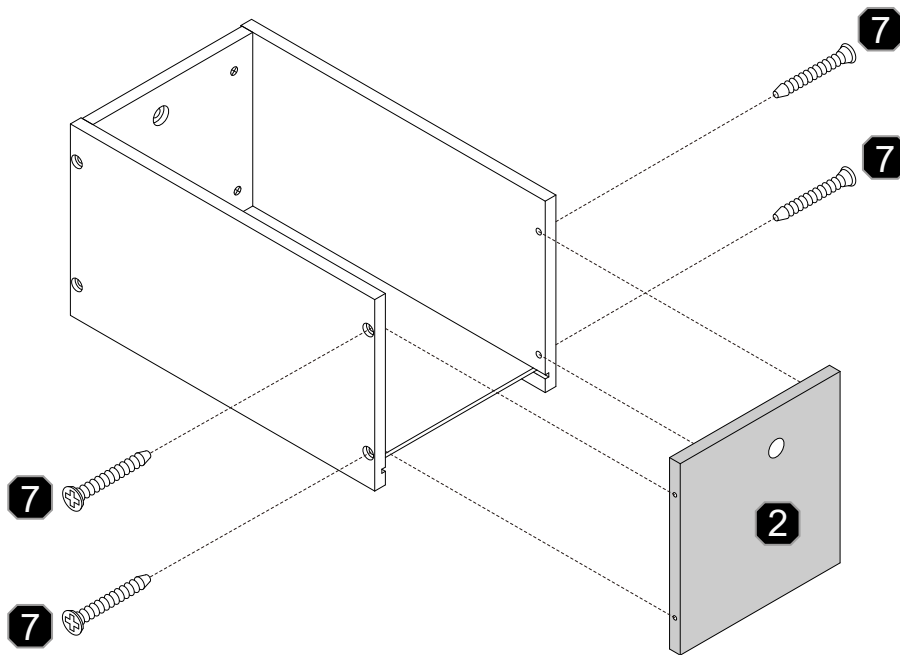

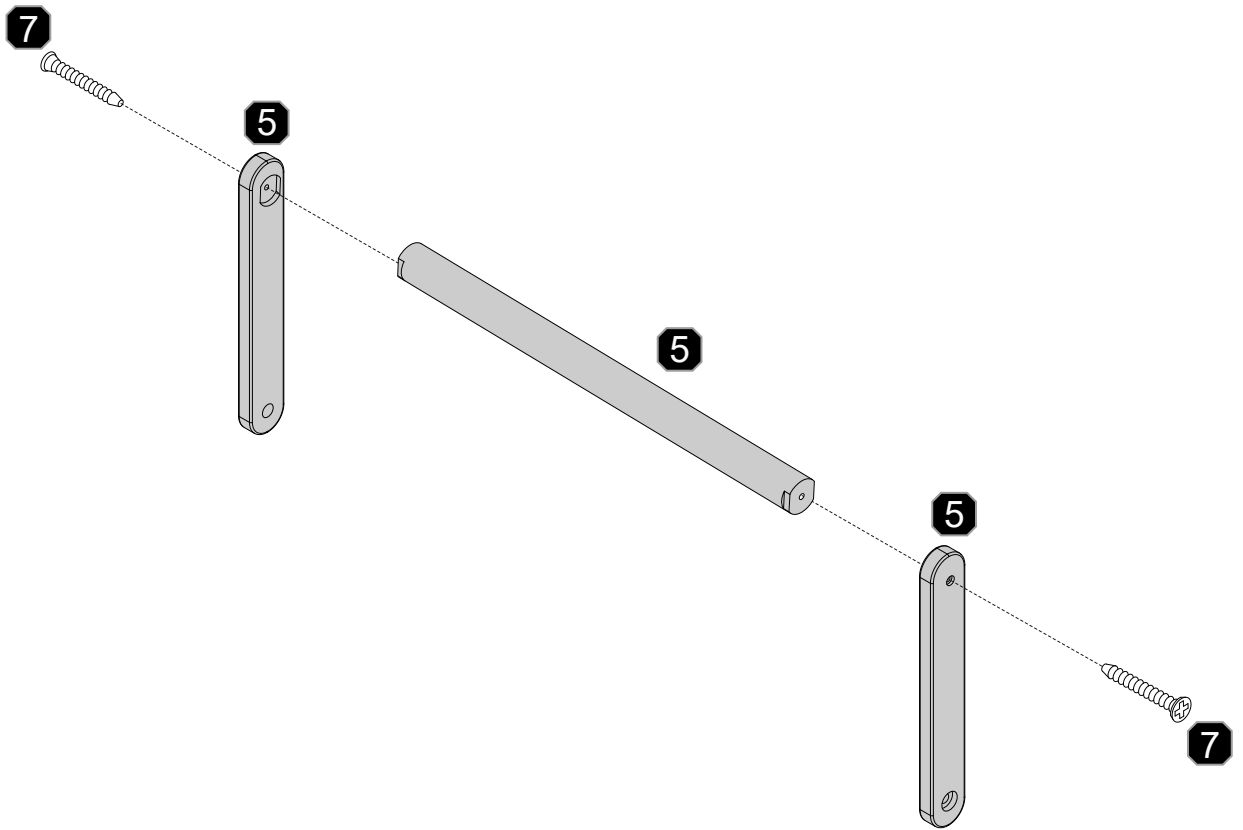
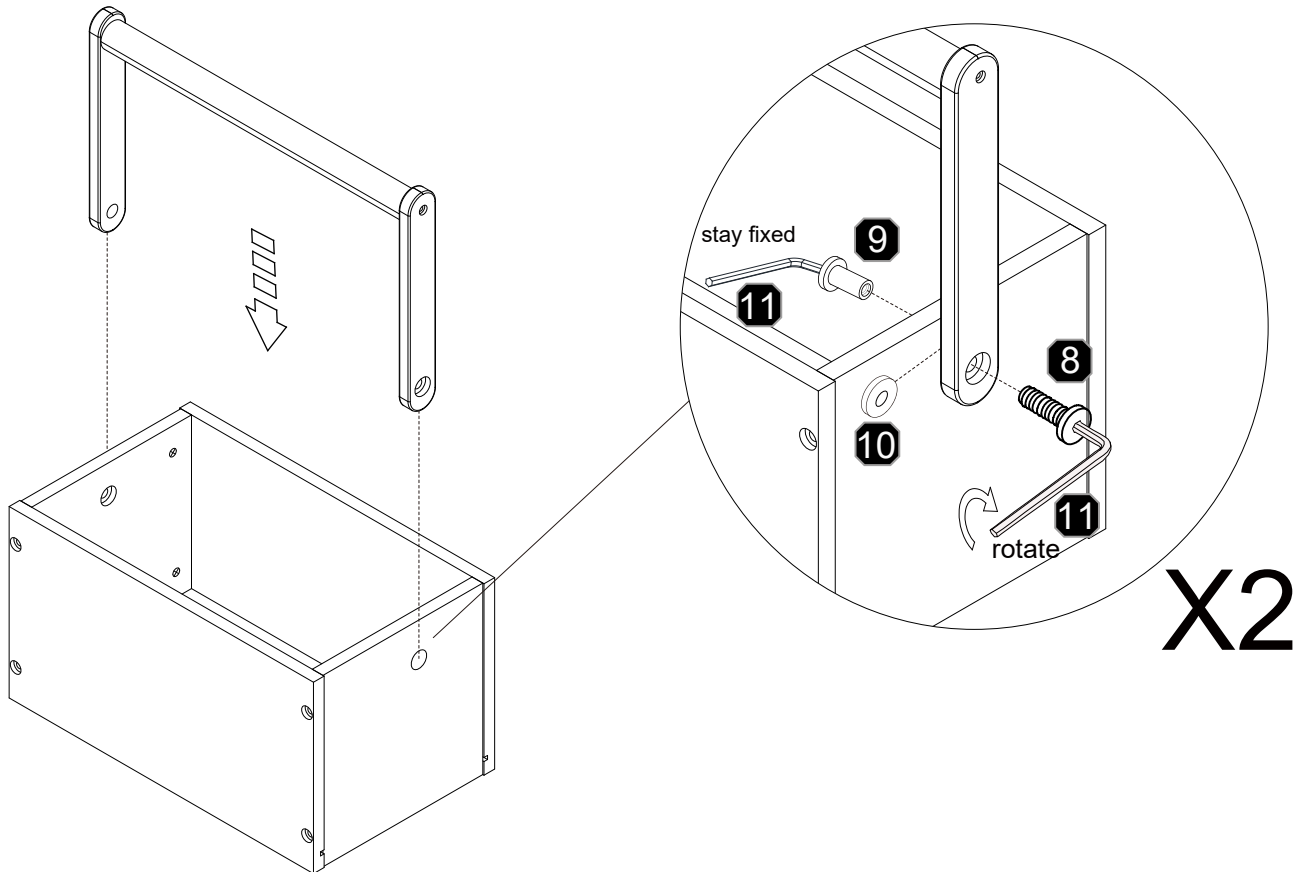
E**F**

G

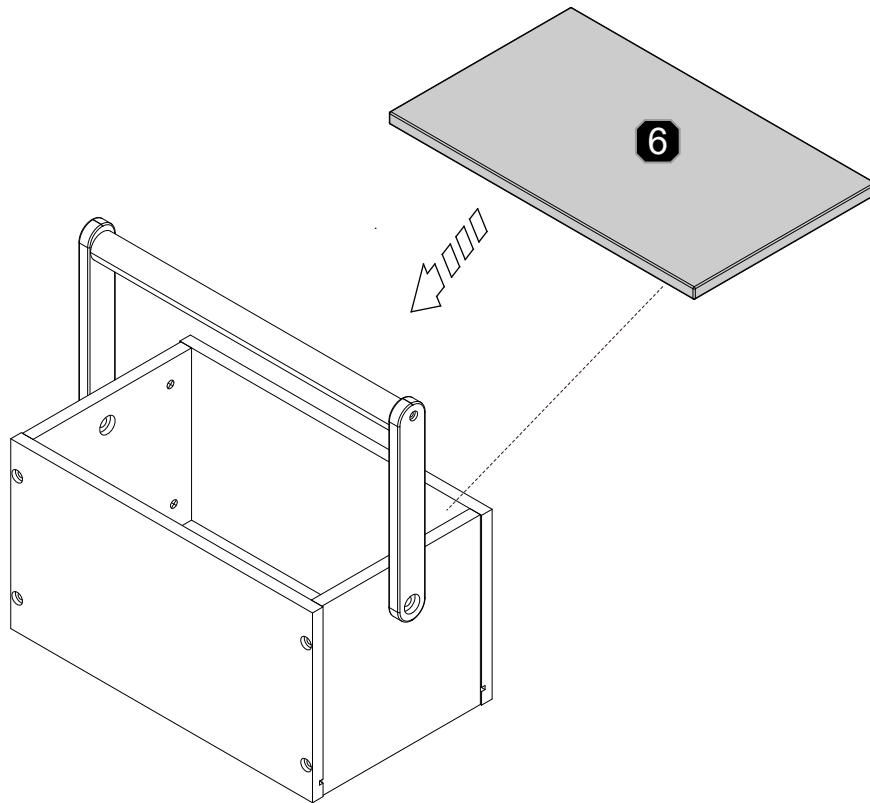

H

